

PaintChecker Reference Samples



For all users who need a particularly high level of security, accuracy and reliability when it comes to measuring thickness, OptiSense Reference Samples, certified by a DAkkS laboratory, are the ideal solution. Precise to the micrometre. Traceable. Quickly ready for mass production.



HIGHLIGHTS

Reference Samples...

- form the basis for reliable measuring results
- are important factors in optimised product quality
- support reliable mass production
- minimise measurement inaccuracies
- meet internationally recognised standards
- guarantee compliance with DIN ISO 9001



PaintChecker

Test Equipment Management

Test equipment management and calibration are essential tools for increasing product quality and avoiding rejects and reworking. Measurement results in line with national standards are an absolute must.

Regulations are, however, becoming more stringent: in certain cases, a company can only be certified according to an international quality standard if it has implemented a reliable procedure for measurement systems analysis (MSA). Reference Samples from OptiSense are what you need.



PaintChecker

Reference Samples

They are variously called reference masters, reference standards, limit gauges, measuring or setting masters or often just zero gauges. In coating technology, they are paint samples with a defined layer of thickness that are put onto a test piece. These are customised products that are given the exact coating that will later be used in production. The Reference Samples are therefore often produced directly from an original component. Our Reference Samples, certified by a DAkkS laboratory, are considered to represent the highest level of measurement accuracy and traceability.



PaintChecker

From Design to Certification

OptiSense knows how to develop and produce Reference Samples perfectly. But only you, as the client, know the production and measurement conditions on site. Designing a Reference Samples is therefore always a joint project.

At least in the initial stages. The result is a highly accurate workpiece and a meaningful, traceable test certificate as proof of the measurement quality achieved for precise device calibration and reliable measurement results, particularly in networked manufacturing processes (Industry 4.0).

Dimensional Drawing Reference Point

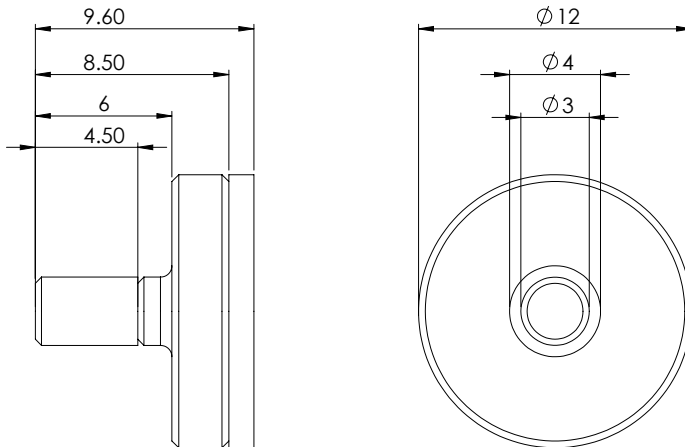

Delivery Contents & Accessories

Delivery Contents

- Number of samples as ordered
- 1 x blank sample (for metal substrate)
- Certificates for the individual samples

Application Example Reference Samples

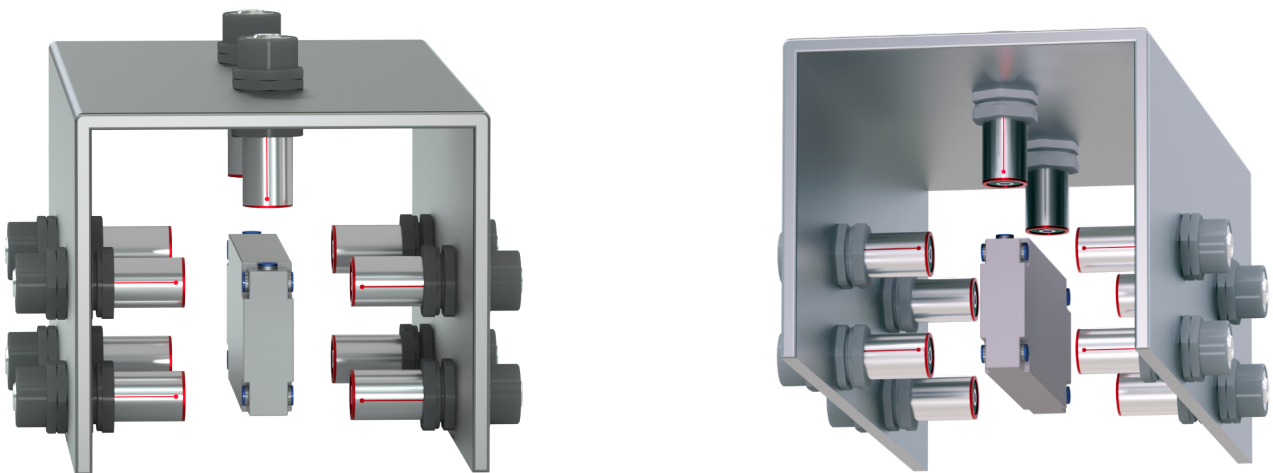

OptiSense is certified according to DIN EN ISO 9001:2015
WEEE-Reg.-No. DE 69647320
Version 22.05

OptiSense GmbH & Co. KG
Annabergstraße 120
45721 Haltern am See
GERMANY

Phone +49 2364 50882-0
Mail info@optisense.com
Web www.optisense.com

